

IntegraLine™

Standard FRP Pipe For Chemical Processing Plants

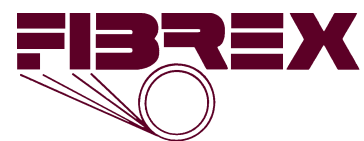

FRP SOLUTIONS MADE SIMPLER™

Introducing IntegraLine* Pipe

After years of serving corrosion-related industries, Fibrex noticed there seemed to be no easy approach to selecting and designing fiberglass reinforced plastic (FRP) pipe. Most plants have worked with fabricators and engineers to custom design all FRP equipment. Yet there is considerable cost and effort to custom design pipe or a pipe system and it is not always necessary.

Fibrex has found there are many applications where a standard FRP pipe product will meet all of the requirements. That's why Fibrex has developed a standard pipe product line called **IntegraLine**.

IntegraLine is a standard production pipe with custom corrosion resistance. Simple to specify and select, this pipe is ideal for new system installation or replacement of existing pipe. **IntegraLine** pipe will meet many of the applications and life-span requirements at your plant or facility.



For special design requirements, Fibrex also offers custom-pipe solutions. Custom-pipe solutions may require thicker corrosion or abrasion barriers with different resins. Also, heavier structural laminates and special glass reinforcements are available to meet installation and temperature requirements.

Fibrex can provide design recommendations for a proposed installation.

And because Fibrex understands the industries we serve, Fibrex products are designed to meet the most demanding and specialized conditions at each site. In standard pipe, custom pipe, special header systems, duct or stacks, Fibrex delivers long-term corrosion solutions and absolute maximum product life. We call this "performance-based manufacturing."

- cost savings
- faster production and quicker delivery
- fast and easy pipe selection

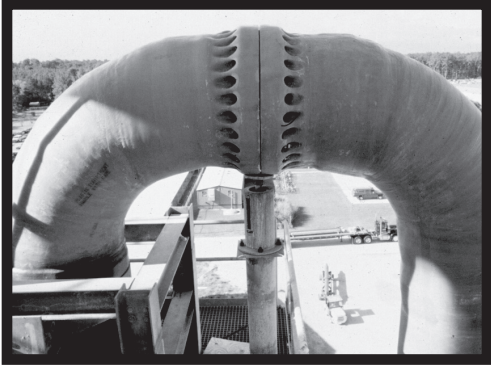

IntegraLine Product Information & Construction Details.....2
 IntegraLine Laminate Construction (illustration)3

Pipe Design and Selection

Pressure Classes - Pipe.....4
 Pressure Classes - Fittings5
 Elbows6
 Reducers7
 Full Face and Blind Flanges.....8
 Stub Ends with Steel Backing Flanges9
 Flanged Joints - Fastener Requirements.....10
 Flanged Joints - Bolting Torque and Sequence.....11
 Fabricated Branch Connections.....12
 Flow Chart.....13

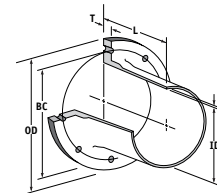
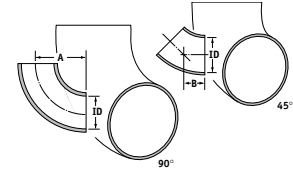

System Design

Supports.....14
 Expansion and Contraction14
 Water Hammer.....15
 Vibration15
 Hydrostatic Testing.....15
 Allowable Spans Between Supports.....16
 System Direction Changes (Offset Legs)18
 Linear Thermal Expansion19
 Minimum Length of Offset Leg19
 Expansion Loops.....20
 Maximum Guide Spacing20
 Compressive End Loads Due to Thermal Expansion21
 Saddle Supports22
 Hanger Supports.....23

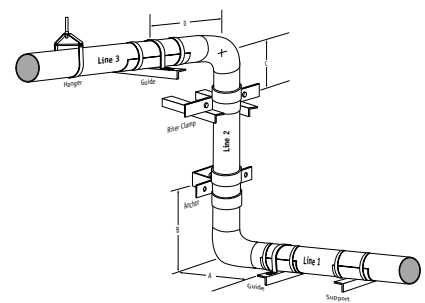
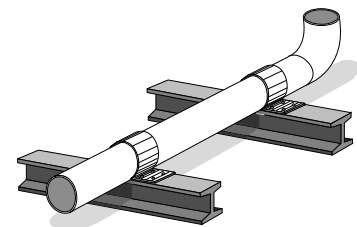

Field Installation

Joining Procedures24
 Field Joint Material Requirements.....27
 Shipping, Handling and Storage.....28

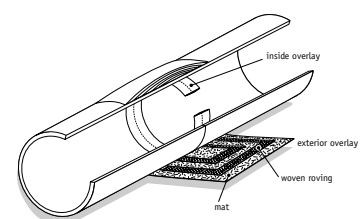

Corrosion Resistance

IntegralLine fiberglass reinforced plastic (FRP) pipe is designed to be “user friendly.” The resin, glass reinforcement materials and composite construction were selected to provide consistent corrosion resistance for the majority of chemical applications for which FRP pipe is considered appropriate. There remain certain extreme chemical services for which special construction and alternative resins should be considered. Fibrex can advise if this is required for your application.

Weather Resistance

IntegralLine pipe utilizes a heavily resinated exterior coat containing an ultraviolet stabilizer to impart long term resistance to the effects of sunlight and other weathering elements. Should pipe become weathered after many years in particularly severe environments, the exterior can be sanded and resin coated or painted.

Color

Pigmented exterior gel coats are not used on **IntegralLine** pipe in order to take advantage of the natural translucency of FRP. Visual inspection of the pipe, both new and after years of service, is more reliable with a “natural” laminate. Additionally, the liquid contents can

often be observed in the pipeline... sometimes a process control advantage. When special color coding is required, however, this can be provided at a nominal added cost and slightly longer delivery time.

Durability

The high tensile elongation properties of the vinyl ester resins utilized in **IntegralLine** pipe impart a superior toughness to the pipe enabling it to resist cracking and crazing of the resin when subjected to heavy design loads. In addition to high fatigue resistance, this toughness also provides a safety factor against impact damage during shipping and installation.

Construction Details

Resin

IntegralLine pipe is manufactured with a premium vinyl ester resin as the standard production resin. Other vinyl ester resins specified by the customer are available, however delivery lead times will generally be longer. Epoxy vinyl ester resins are premium corrosion resistant resins. At both room and elevated temperatures, these resins offer resistance to a broad range of acids, alkalis, bleaches and solvents making them the appropriate choice of resins in many chemical processing industry applications. These resins, when properly formulated and cured, comply with FDA regulation 21 CFR 177.2420 covering materials intended for repeated use in contact with food. Specific chemical resistance information can be found in the Chemical Resistance and Engineering Guides, available from FIBREX or directly from the resin manufacturers.

Reinforcement Materials

A “C” glass (chemical grade) veil is provided on all surfaces exposed to corrosive media. Fiberglass used in all subsequent layers of the laminate has excellent electrical resistivity, high tensile strength, moderate thermal conductivity and is noncombustible. The basic types of fiberglass materials used; mat, woven roving and continuous strand, are selected for their physical properties, manufacturing characteristics and the chemical resistance of the laminate resulting from their use.

Corrosion Barrier

The corrosion barrier of **IntegralLine** pipe is nominally 100 mils thick and is comprised of 70% to 80% resin. This highly resinated laminate is reinforced by one layer of “C” glass veil followed by two layers of randomly oriented fiber strand mat.

Structural Laminate

Straight Pipe

IntegralLine pipe is manufactured by the filament winding process utilizing continuous fiberglass strand wound in a helical pattern at a nominal 55 degree wind angle to produce an optimum combination of hoop and axial properties for most typical applications. The high glass content resulting from the filament winding process imparts excellent strength characteristics to the laminate providing superior protective structural backup to the resin rich corrosion barrier.

Fittings

IntegralLine pipe fittings are manufactured utilizing a highly efficient contact-molded laminate consisting of alternating layers of glass fiber strand mat and bi-directional woven glass roving. The high glass content resulting from the specific laminating process used for **IntegralLine** pipe fittings permits the wall thickness of this hand-layup process to closely approximate the wall thickness of filament wound straight pipe in equivalent pressure rated classes.

Filament Wound Laminate

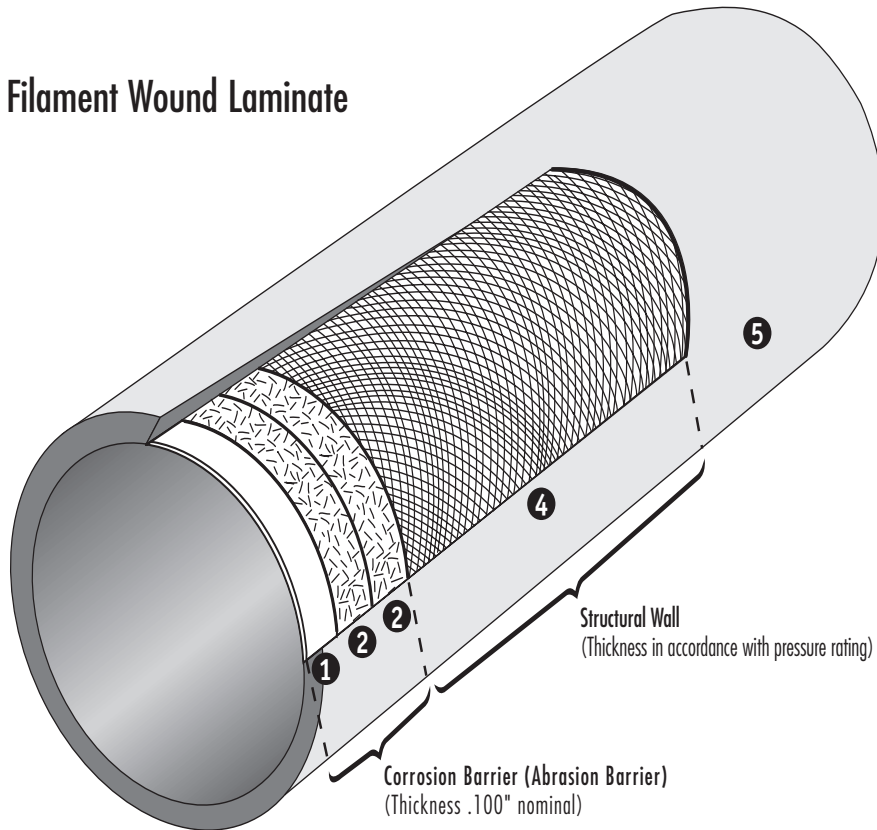

Note: Corrosion/Abrasion Barrier may be thicker for specific applications.

- 1 C-Glass surface veil
- 2 Chopped Strand Mat
- 3 Woven Roving
- 4 Filament Wound Strand
- 5 Outer surface layer with U.V. inhibitor

Contact Molded Laminate

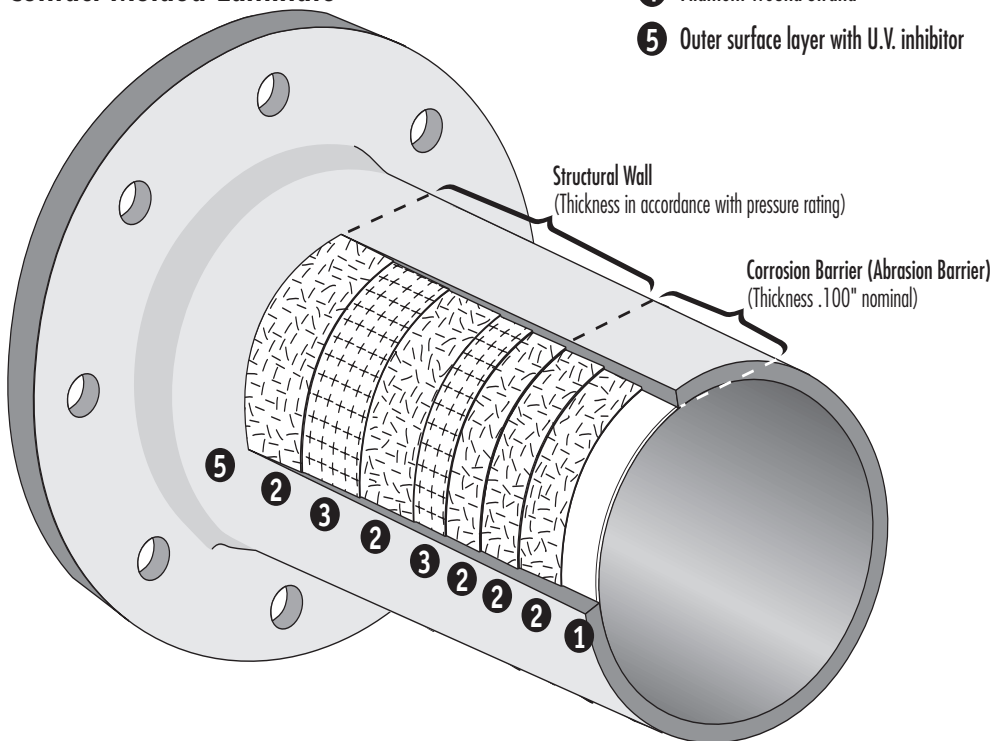

Pipe Design & Selection

Pressure Classes:
Filament
Wound Pipe

50 PSI

Diameter (in.)	Total Wall Thickness (in.)	Unit Weight (lb.)	Allowable Vacuum (psi)	Max. Type I Simple Span* (ft.)
6	0.21	2.74	5.80	14.7
8	0.21	3.69	2.50	13.9
10	0.21	4.57	1.28	13.0
12	0.21	5.46	0.73	12.0
14	0.21	6.35	0.46	10.7
16	0.26	9.23	0.92	14.8
18	0.26	10.36	0.64	13.9
20	0.26	11.49	0.47	12.9
24	0.31	16.73	0.60	15.7
30	0.31	20.83	0.31	12.8
36	0.36	29.38	0.33	15.0

100 PSI

Diameter (in.)	Total Wall Thickness (in.)	Unit Weight (lb.)	Allowable Vacuum (psi)	Max. Type I Simple Span* (ft.)
6	0.21	2.74	5.90	11.5
8	0.24	4.31	5.00	12.5
10	0.26	5.85	3.78	13.0
12	0.29	7.90	3.60	14.0
14	0.31	9.88	3.06	14.0
16	0.34	12.46	3.03	15.0
18	0.36	14.89	2.70	15.5
20	0.41	19.02	3.30	17.0
24	0.46	25.74	2.97	18.0
30	0.56	39.53	3.20	19.5
36	0.62	52.66	2.63	20.5

150 PSI

Diameter (in.)	Total Wall Thickness (in.)	Unit Weight (lb.)	Allowable Vacuum (psi)	Max. Type I Simple Span* (ft.)
6	0.23	3.05	9.60	11.0
8	0.27	4.93	8.80	12.5
10	0.32	7.40	9.60	13.0
12	0.36	10.05	9.10	14.5
14	0.39	12.74	7.90	15.0
16	0.43	16.13	7.70	15.5
18	0.47	19.92	7.68	16.5
20	0.50	23.58	7.00	17.5
24	0.58	33.02	7.00	18.5
30	0.68	48.61	6.30	20.5
36	0.81	69.87	6.65	23.0

*Based on fluid contents specific gravity of 1.2

Pressure Classes:
Contact Molded
Pipe & Fittings

50 PSI

D Diameter	Pipe Total Wall Thickness	Pipe Unit Weight	Full Face Flange Thickness	U N I T W E I G H T S			
				90 Ell	Full Face Flange	Stub End Flange	Reducer (1 size red.)
2	0.19	0.8	1/2	0.3	1.4	0.6	
3	0.19	1.1	1/2	0.7	2.1	0.8	0.2
4	0.19	1.5	9/16	1.2	3.1	1.2	0.3
6	0.19	2.2	5/8	2.6	4.8	2.0	0.8
8	0.19	3.0	3/4	4.8	7.2	2.8	1.2
10	0.24	4.8	7/8	9.6	12.9	5.1	1.6
12	0.24	5.8	1	13.8	18.6	6.8	2.2
14	0.24	6.7	1-1/16	18.6	23.6	8.7	2.6
16	0.30	9.7	1-3/16	30.8	32.5	12.4	3.4
18	0.30	10.9	1-1/4	38.8	36.1	13.9	4.3
20	0.30	12.1	1-5/16	47.8	43.0	15.7	4.8
24	0.35	17.0	1-1/2	80.7	61.7	21.8	12.1
30	0.41	25.1	1-7/8	148.2	108.3	39.0	26.3
36	0.46	33.8	2-3/16	239.9	163.4	54.2	36.8

100 PSI

D Diameter	Pipe Total Wall Thickness	Pipe Unit Weight	Full Face Flange Thickness	U N I T W E I G H T S			
				90 Ell	Full Face Flange	Stub End Flange	Reducer (1 size red.)
2	0.19	0.8	9/16	0.3	1.6	0.6	
3	0.19	1.1	11/16	0.7	2.7	0.8	0.2
4	0.19	1.5	13/16	1.2	4.2	1.2	0.3
6	0.24	2.9	7/8	3.4	6.6	2.6	0.9
8	0.30	5.0	1	7.9	10.7	4.5	1.7
10	0.30	6.2	1-3/16	12.3	17.6	6.8	2.3
12	0.35	8.7	1-7/16	20.7	27.9	10.1	3.1
14	0.41	11.9	1-1/2	33.1	36.9	15.4	4.3
16	0.46	15.3	1-5/8	48.5	48.0	20.4	5.7
18	0.46	17.2	1-3/4	61.1	54.4	21.8	6.8
20	0.52	21.6	1-7/8	85.5	68.6	27.9	8.1
24	0.63	31.6	2-1/8	149.7	99.4	41.6	22.2
30	0.74	46.5	2-1/2	274.8	167.8	74.4	48.8
36	0.85	64.1	2-13/16	454.6	246.1	104.9	69.1

150 PSI

D Diameter	Pipe Total Wall Thickness	Pipe Unit Weight	Full Face Flange Thickness	U N I T W E I G H T S			
				90 Ell	Full Face Flange	Stub End Flange	Reducer (1 size red.)
2	0.19	0.8	11/16	0.3	1.8	0.6	
3	0.24	1.5	13/16	0.9	3.3	1.1	0.2
4	0.24	2.0	15/16	1.5	5.0	1.5	0.4
6	0.30	3.7	1-1/16	4.4	8.2	3.4	1.2
8	0.35	5.9	1-1/4	9.4	13.3	5.3	2.1
10	0.46	9.8	1-7/16	19.4	23.7	10.7	3.3
12	0.52	13.3	1-3/4	31.6	37.1	15.3	4.8
14	0.57	16.9	1-7/8	47.0	49.4	21.7	6.3
16	0.63	21.4	2-1/16	67.7	64.7	28.3	8.0
18	0.68	26.0	2-1/4	92.4	76.6	32.8	9.9
20	0.74	31.4	2-7/16	124.1	96.1	40.3	12.0
24	0.85	43.3	2-13/16	205.1	139.2	56.7	31.1
30	1.07	68.3	3-3/8	404.0	245.4	108.9	69.7
36	1.23	94.2	4	668.1	376.8	153.6	101.6

Pipe total wall thickness is based on high-strength laminate (HSL) using 3/4 oz mat / 24 oz woven roving in structural layers.

Long Radius 90°/45° Elbows

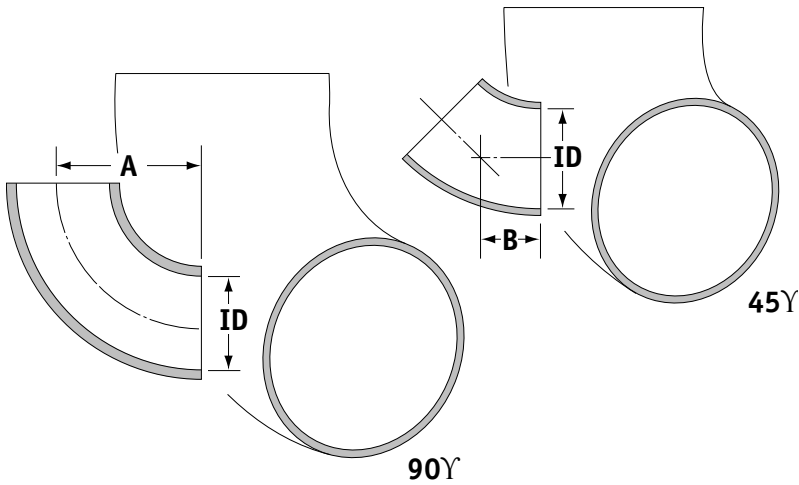

NOTE: 1. Dimension A (90°), or B (45°) can be reduced with mitered construction.

90° Elbow

ID Diameter	A
2	4
3	6
4	6
6	9
8	12
10	15
12	18
14	21
16	24
18	27
20	30
24	36
30	45
36	54

45° Elbow

ID Diameter	B
2	1-5/8
3	2-1/2
4	2-1/2
6	3-3/4
8	5
10	6-1/4
12	7-1/2
14	8-3/4
16	10
18	11-1/4
20	12-1/2
24	15
30	18-5/8
36	22-3/8

Optional Flanged Elbows

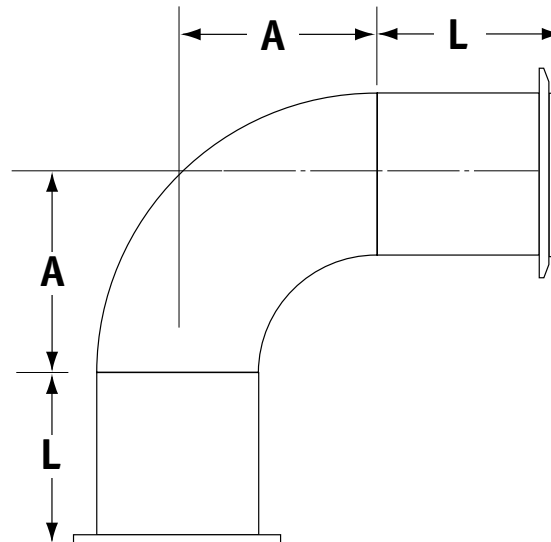

NOTES: 1. L = Standard Stub length unless specific length is requested.
2. Elbow with either full face flanges or flanges with steel backing rings.

3. Elbows can be provided with flange laminated to the pre-manufactured elbow, however these should be used only as a necessary alternative to the preferred configuration shown.

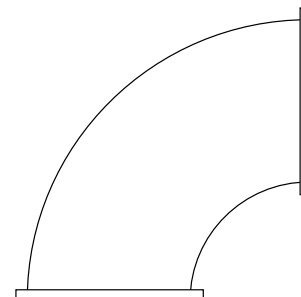

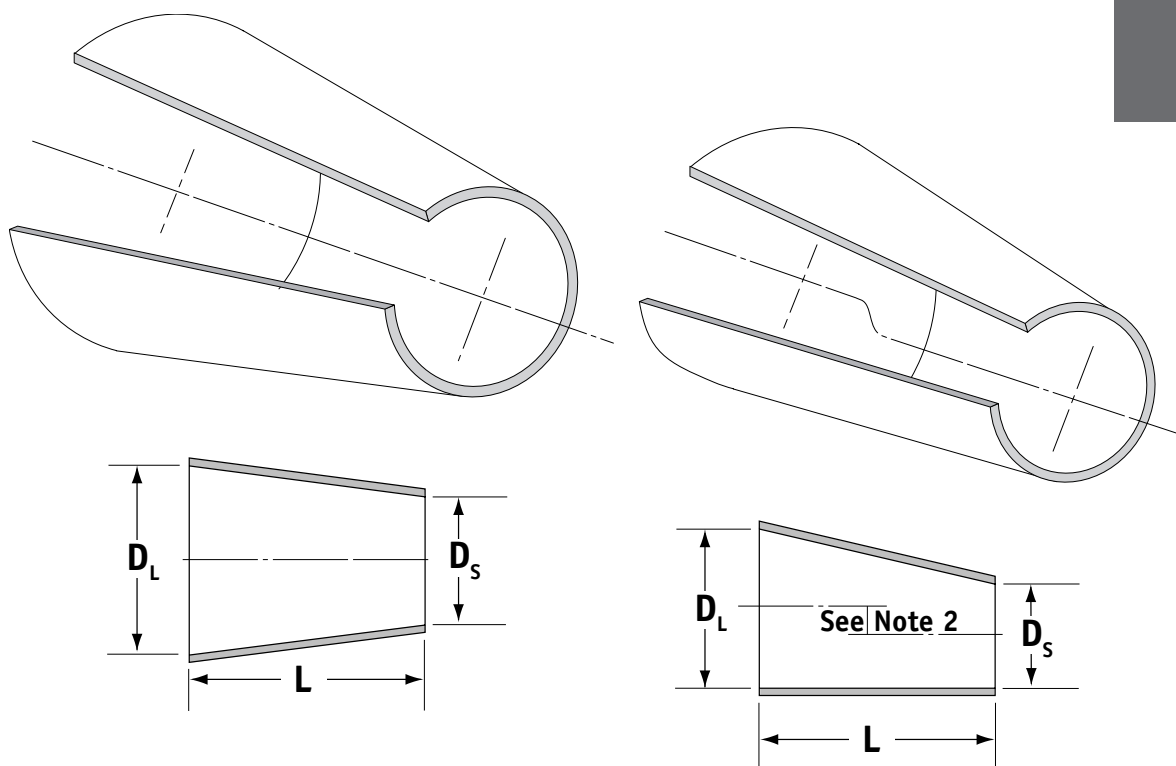

Notes: 1. Formula for length of reducer $L=2 \cdot 1/2 (D_L - D_S)$

2. Formula for eccentric offset $E = \frac{D_L - D_S}{2}$

3. For length of standard flange see appropriate flange table.

4. Lengths other than those shown are available.

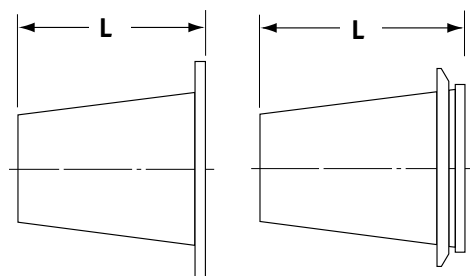

Reducers with full face flanges

The large end of the reducer can be provided in flanged configuration.

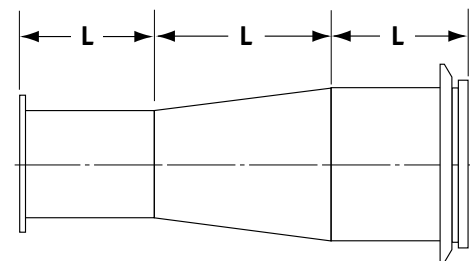

Reducers are available with either full face flanges or stub flanges with steel backing rings.

Pipe Design & Selection

Full Face and Blind Flanges

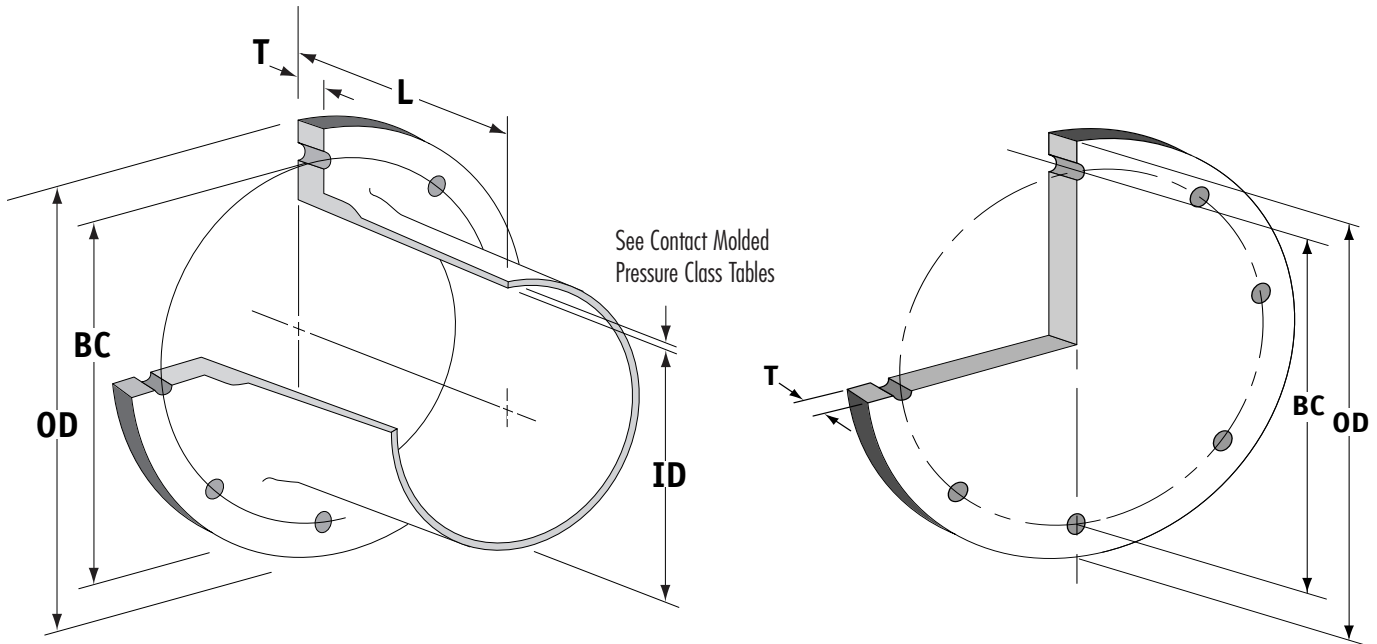

ID Diameter	OD* Outside Diameter	Number of Holes	Diameter of Holes	BC Bolt circle	Flange Thickness			L Stub Length
					50 PSI	100 PSI	150 PSI	
1 - 1/2	5	4	5/8	3-7/8	1/2	9/16	11/16	6
2	6	4	3/4	4 - 3/4	1/2	9/16	11/16	6
2 - 1/2	7	4	3/4	5 - 1/2	1/2	11/16	3/4	6
3	7 - 1/2	4	3/4	6	1/2	11/16	13/16	6
4	9	8	3/4	7 - 1/2	9/16	13/16	15/16	6
6	11	8	7/8	9 - 1/2	5/8	7/8	1 - 1/16	8
8	13 - 1/2	8	7/8	11 - 3/4	3/4	1	1 - 1/4	8
10	16	12	1	14 - 1/4	7/8	1 - 3/16	1 - 7/16	10
12	19	12	1	17	1	1 - 7/16	1 - 3/4	10
14	21	12	1 - 1/8	18 - 3/4	1 - 1/16	1 - 1/2	1 - 7/8	12
16	23 - 1/2	16	1 - 1/8	21 - 1/4	1 - 3/16	1 - 5/8	2 - 1/16	12
18	25	16	1 - 1/4	22 - 3/4	1 - 1/4	1 - 3/4	2 - 1/4	12
20	27 - 1/2	20	1 - 1/4	25	1 - 5/16	1 - 7/8	2 - 7/16	12
24	32	20	1 - 3/8	29 - 1/2	1 - 1/2	2 - 1/8	2 - 13/16	12
30	38 - 3/4	28	1 - 3/8	36	1 - 7/8	2 - 1/2	3 - 3/8	15
36	46	32	1 - 5/8	42 - 3/4	2 - 3/16	2 - 13/16	4	15

*Tolerance on O.D. is $\begin{matrix} -0'' \\ +1/2'' \end{matrix}$

Flange drilling per ANSI B16.1, Class 125 (identical to ANSI B16.5, Class 150 through 24" dia.)

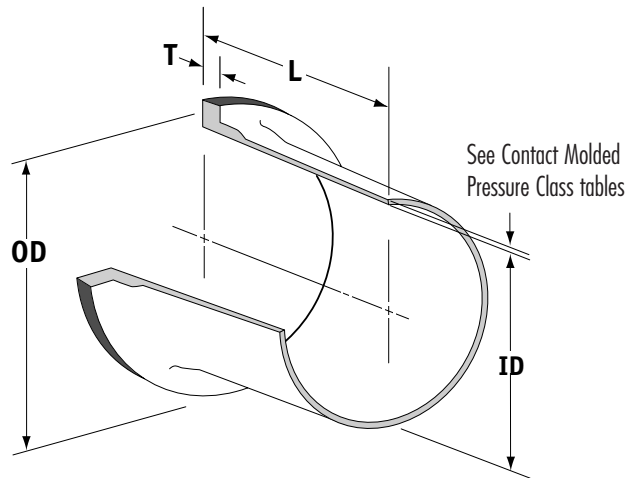

Tapered



All pressures up through 6" and all 50 PSI

Flat



100 - 150 PSI
8" and larger

Stub Ends with Steel Backing Flanges

Stub End

ID Diameter	OD Outside Diameter	Flange Thickness			L Stub Length
		50 PSI	100 PSI	150 PSI	
2	4	1/2	1/2	1/2	6
3	5 - 1/4	1/2	1/2	9/16	6
4	6 - 3/4	1/2	9/16	5/8	6
6	8 - 5/8	1/2	9/16	3/4	8
8	10 - 7/8	1/2	11/16	7/8	8
10	13 - 1/4	9/16	13/16	1	10
12	16	9/16	15/16	1 - 5/16	10
14	17 - 5/8	5/8	1 - 1/16	1 - 3/8	12
16	20 - 1/8	5/8	1 - 1/16	1 - 1/2	12
18	21 - 1/2	3/4	1 - 1/8	1 - 5/8	12
20	23 - 3/4	3/4	1 - 1/4	1 - 5/8	12
24	28 - 1/8	7/8	1 - 1/2	1 - 3/4	12
30	34 - 5/8	15/16	1 - 11/16	2 - 5/16	15
36	41 - 1/8	1 - 1/16	2	2 - 5/8	15

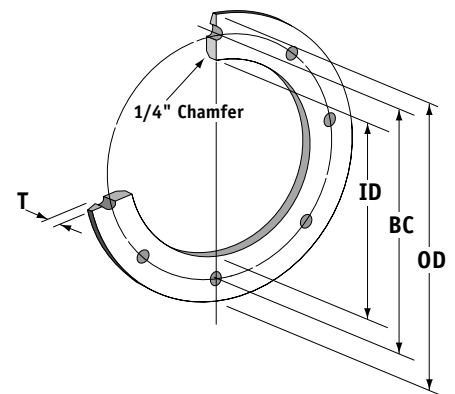

Steel Backing Flange

Pipe Diameter	50psi	ID Inside Diameter 100psi 150psi	OD Outside Diameter	BC Bolt Circle Diameter	Number of Holes	Diameter of Holes	Thickness	Approx. Weight*
2	2 - 5/8	ID's are for	6	4 - 3/4	4	3/4	5/8	2.8
3	3 - 3/4	SK-39-SO	7 - 1/2	6	4	3/4	5/8	4.5
4	4 - 3/4	or	9	7 - 1/2	8	3/4	5/8	6.5
6	7	SK-70-SO	11	9 - 1/2	8	7/8	3/4	9.5
8	9		13 - 1/2	11 - 3/4	8	7/8	3/4	12.5
10	11 - 1/8		16	14 - 1/4	12	1	7/8	19
12	13 - 1/8	SK-70-PSO	19	17	12	1	7/8	28
14	15		21	18 - 3/4	12	1 - 1/8	1	32
16	17		23 - 1/2	21 - 1/4	16	1 - 1/8	1	42
18	19	SPECIAL BORE	25	22 - 3/4	16	1 - 1/4	1 - 1/8	50
20	21		27 - 1/2	25	20	1 - 1/4	1 - 1/8	58
24	25		32	29 - 1/2	20	1 - 3/8	1 - 1/8	82
30	31 - 1/4		38 - 3/4	36	28	1 - 3/8	1 - 1/4	130
36	37 - 1/4		46	42 - 3/4	32	1 - 5/8	1 - 1/4	175

*Weight varies with inside Diameter

Pipe Design & Selection

Flanged Joints - Fastener Requirements

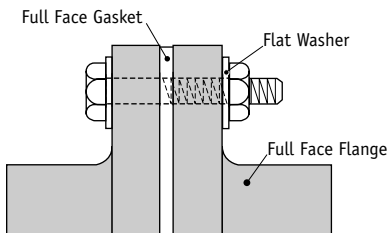

FULL FACE FLANGE CONNECTION

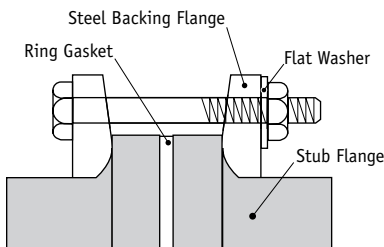

STUB FLANGE WITH STEEL BACKING FLANGE CONNECTION

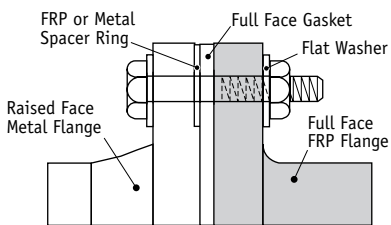

METAL RAISED FACE FLANGE TO FULL FACE FRP FLANGE CONNECTION

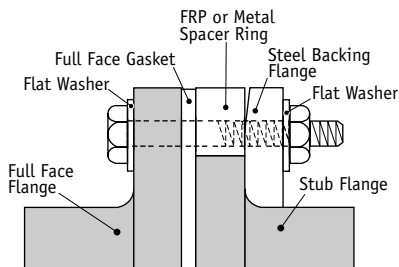

FULL FACE FLANGE TO STUB FLANGE WITH STEEL BACKING RING CONNECTION

NOTES: 1. Use full face or ring gasket as indicated in sketches.
2. Do not connect full face flanges to raised face or stub flanges without a spacer ring.

Flange Diameter	Rated Pressure	Flange Thickness	Quantity Required	Diameter	Bolt Length
2	50	1/2	4	5/8	2 - 1/4
	100	9/16	4	5/8	2 - 1/2
	150	11/16	4	5/8	2 - 3/4
3	50	1/2	4	5/8	2 - 1/4
	100	11/16	4	5/8	2 - 3/4
	150	13/16	4	5/8	3
4	50	9/16	8	5/8	2 - 1/2
	100	13/16	8	5/8	3
	150	15/16	8	5/8	3 - 1/4
6	50	5/8	8	3/4	2 - 3/4
	100	7/8	8	3/4	3 - 1/4
	150	1 - 1/16	8	3/4	3 - 1/2
8	50	3/4	8	3/4	3
	100	1	8	3/4	3 - 1/2
	150	1 - 1/4	8	3/4	4
10	50	7/8	12	7/8	3 - 1/4
	100	1 - 3/16	12	7/8	4
	150	1 - 7/16	12	7/8	4 - 1/2
12	50	1	12	7/8	3 - 1/2
	100	1 - 7/16	12	7/8	4 - 1/2
	150	1 - 3/4	12	7/8	5
14	50	1 - 1/16	12	1	4
	100	1 - 1/2	12	1	5
	150	1 - 7/8	12	1	5 - 3/4
16	50	1 - 3/16	16	1	4 - 1/4
	100	1 - 3/4	16	1	5 - 1/2
	150	2 - 1/16	16	1	6
18	50	1 - 1/4	16	1 - 1/8	4 - 1/2
	100	1 - 3/4	16	1 - 1/8	5 - 1/2
	150	2 - 1/4	16	1 - 1/8	6 - 1/2
20	50	1 - 5/16	20	1 - 1/8	4 - 3/4
	100	1 - 7/8	20	1 - 1/8	5 - 3/4
	150	2 - 7/16	20	1 - 1/8	7
24	50	1 - 1/2	20	1 - 1/4	5 - 1/4
	100	2 - 1/8	20	1 - 1/4	6 - 1/2
	150	2 - 13/16	20	1 - 1/4	8
30	50	1 - 7/8	28	1 - 1/4	6
	100	2 - 1/2	28	1 - 1/4	7 - 1/4
	150	3 - 3/8	28	1 - 1/4	9
36	50	2 - 3/16	32	1 - 1/2	7
	100	2 - 13/16	32	1 - 1/2	8 - 1/4
	150	4	32	1 - 1/2	10 - 1/2

NOTES: 1. Bolt lengths are calculated for full face FRP flanges. Length requirements for stub ends with steel backing flanges may vary and should be verified with FIBREX.

2. Bolt lengths are adequate for (2) washers plus heavy hex nut and 1/8" thick gasket with excess of 3/8"-1/2".

3. Use ANSI Type A Narrow or Type B Narrow plain washers.

4. Use gaskets with Shore A durometer of 50-60. Gaskets should be 1/8" minimum thickness up through 24" diameter and 3/16" for 30 and 36" diameter.

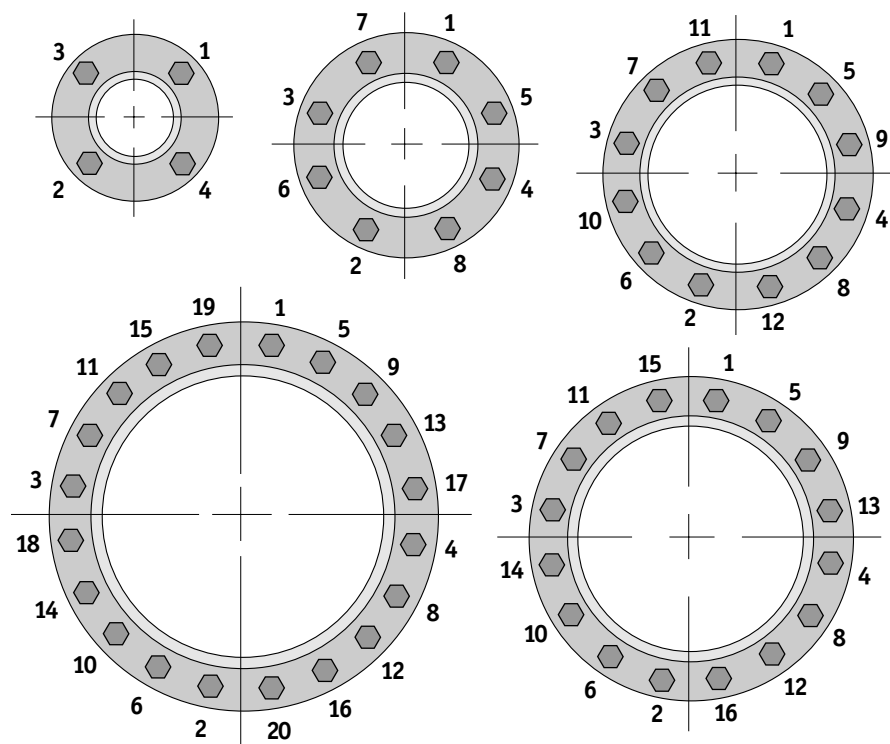

1. Gaskets should have a Shore A durometer of 50-60 with the following minimum thickness; 1/8" thru 20" diameter, 3/16" - 24" - 36" diameter.

2. Bolts should initially be tightened to 50% of the values shown. Subsequent tightening should be in the same sequence until the required torque is reached.

Typical Bolt Torque Force Required for Sealing

Pipe Diameter in.	50 PSI	100 PSI	150 PSI
2	25	25	25
3	25	25	25
4	25	25	25
6	25	25	40
8	25	40	60
10	25	40	70
12	25	45	80
14	30	60	100
16	30	70	120
18	35	80	130
20	35	90	140
24	40	100	150
30	45	120	175
36	50	140	200

NOTE: The indicated torque is suggested to seal flanges in pressure pipe using gaskets of a Shore A durometer of 50 to 60.

Maximum Bolt Torque for Pressure Piping

Bolt Size in.	Torque ft. - lb.
1/2	15
5/8	25
3/4	40
7/8	65
1	100
1 - 1/8	140
1 - 1/4	200
1 - 1/2	320
1 - 3/4	600
2	880

Based on a 12,000 psi bolt stress. Use ANSI Type A Narrow or Type B Narrow plain washers.

Pipe Design & Selection

Fabricated Branch Connections

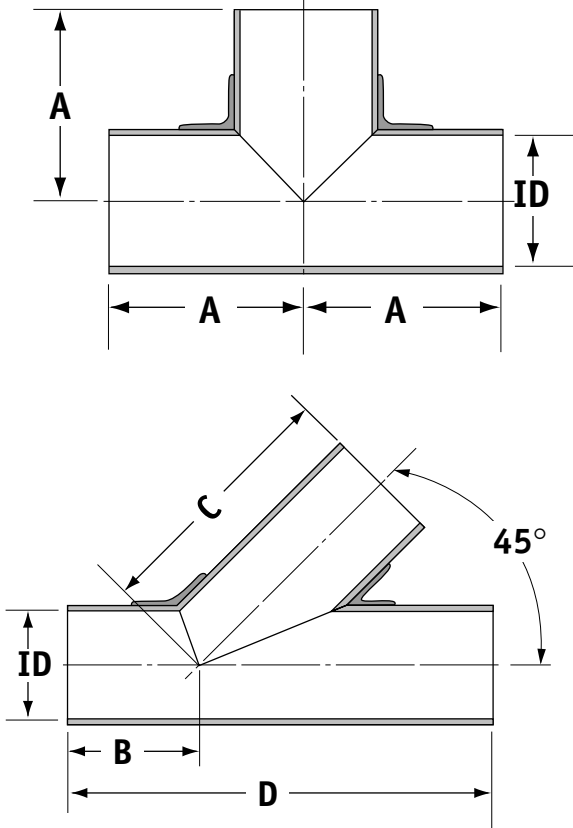

ID Diameter	A	B	C	D
2	6	6	10	16
3	7	6	12	18
4	8	6	14	20
6	10	8	16	24
8	12	10	20	30
10	14	10	24	34
12	16	12	26	38
14	18	12	30	42
16	20	14	32	46
18	21	14	36	50
20	22	16	38	54
24	24	18	42	60
30	30	20	52	72
36	33	22	62	84

NOTES: 1. A is the minimum recommended length to allow for a joint overlay.
 2. Tees, including reducing tees, are not one-piece construction but are manufactured by joining one section of pipe into the sidewall of another. For this reason it is rarely of benefit to order a tee fitting as an individual component. The main run of pipe can be provided with the required branch line stub thereby saving shop and field joints.

Pipe Coupling Connection

NPT	A
1/4	3"
3/8	3"
1/2	3-1/2"
3/4	3-1/2"
1	4"
1-1/4	4"
1-1/2	4-1/2"

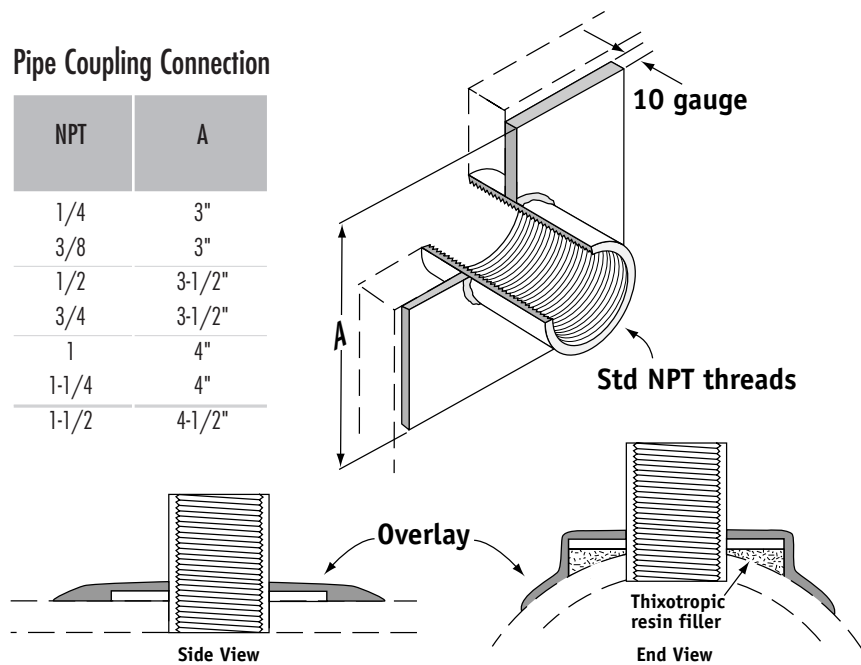

Head Loss vs. Flow Rate

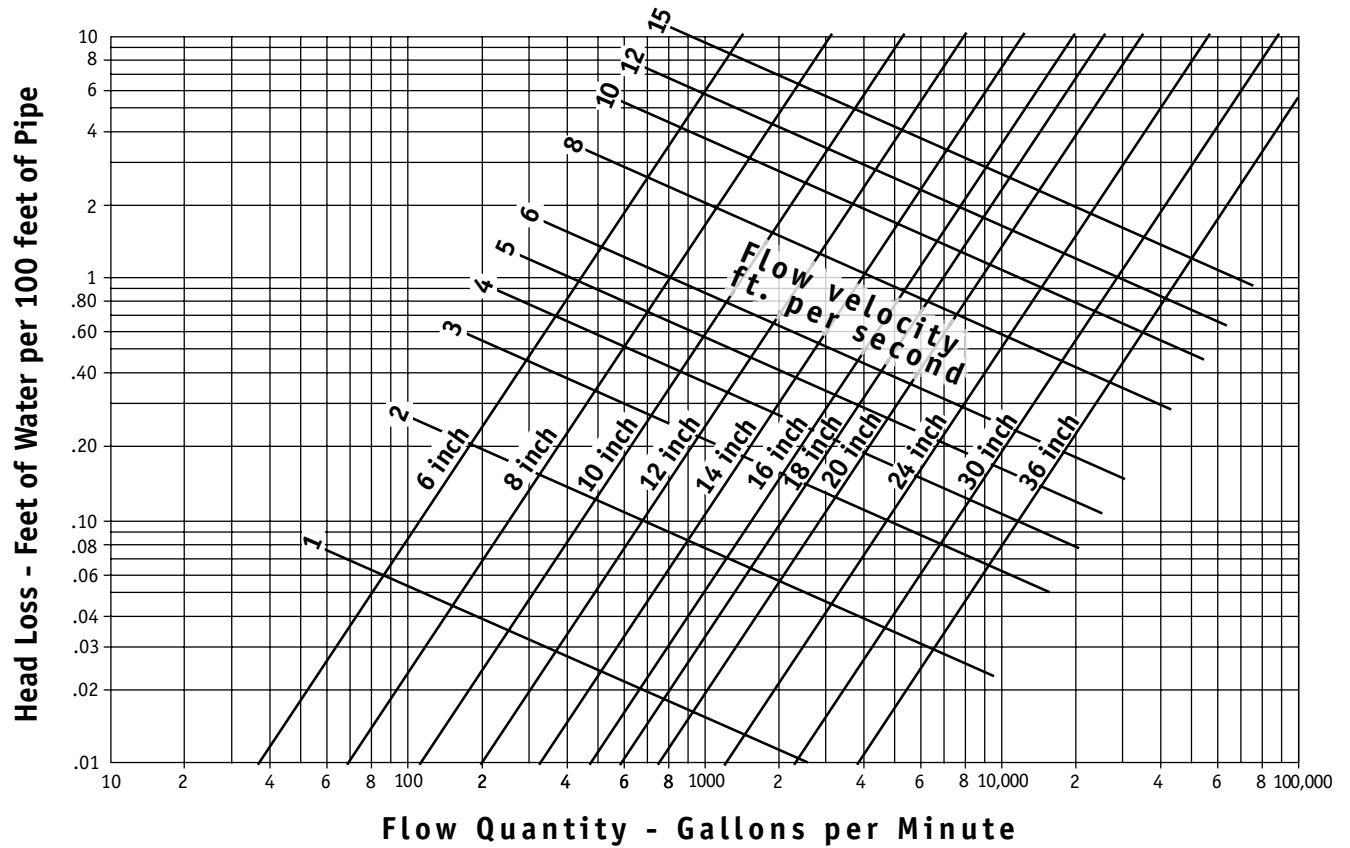

Friction Losses of Fittings in Equivalent Length of Straight Pipe

Fitting - Diameter	2	3	4	6	8	10	12	14	16	18	20	24	30	36
90 Smooth Turn Ell	3	4	5	8	11	13	16	17	20	23	25	30	37	45
45 Smooth Turn Ell	2	2	3	4	6	7	9	10	11	12	14	17	21	25
Tee - Through Flow	4	5	7	10	14	17	20	22	25	28	32	38	47	57
Tee - Branch Flow	11	16	20	30	40	50	60	66	75	85	95	113	140	170

IntegralLine pipe has excellent corrosion resistance and mechanical properties. However, as with any piping material, good application design and installation practices will greatly enhance the reliability and service life of the pipe system.

The following suggestions describe a rudimentary approach to laying out the piping system. This approach does not include all possible contingencies and is not intended to replace more extensive design approaches, such as finite element analysis, when the designer judges these to be appropriate.

Supports

1. Select preliminary support locations. Steel supports for **IntegralLine** pipe should be spaced at maximum intervals shown in the tables on page 17. These distances should not be exceeded. A reduction of 10% in the distance between supports should be considered when:

- (a) pipe is carrying fluids with specific gravities in the range of 1.1 to 1.3
- (b) fluid contents of the pipe may be over 180 degrees Fahrenheit
- (c) wind loads, vibration or other factors present may increase loads on the pipe run

2. Use support saddles of adequate size to eliminate the possibility of point loading. A good rule of thumb is that saddles should provide complete 180 degree support of the lower half of the pipe. Saddle length should be equal to the diameter of the pipe for small sizes and not less than two thirds the diameter of the pipe for larger sizes.

3. Valves, pumps, and other heavy equipment connected to the pipe should be supported independently to avoid imposing excessive loads on the pipe.

4. Vertical pipe runs should be supported from below so that pipe is "in compression".

5. A minimum 1/8" thick layer of neoprene or other elastomeric material should be provided between the pipe and the steel support saddle to insure maximum contact and to prevent abrasion. Thicker layers may be used to fill any excess space between the outside wall of the pipe and the interior curvature of the saddle.

6. When long runs of pipe are hung from overhead structures, guides should be incorporated periodically (every third or fourth hanger location) to provide lateral stability.

Expansion & Contraction

IntegralLine pipe expands in the axial direction at approximately twice the rate of steel. However, because it has a relatively low axial modulus of elasticity, thermal forces are smaller and therefore restraining anchors and guides need not be as heavy as for steel pipe.

Common practice for above-ground piping systems is to provide anchors at approximately 300 ft. intervals. This helps to prevent pipe movement due to vibration or water hammer. In addition to the natural anchor points in the system, such as equipment connections, it is a good idea to provide anchors

at transition points where changes in pipe diameter, direction or elevation, material of construction or major branch connections occur. This serves to divide the piping system into individual expanding sections that are simpler to deal with.

Expansion and contraction are usually handled by one or a combination of the following methods:

1. Directional Changes in the System.

When sufficient flexibility exists within the piping system layout, using directional changes is generally the least expensive means to accommodate expansion and contraction. A typical approach to this method is described on page 18.

2. Mechanical Expansion Joints. Various types of expansion joints are used successfully with FRP pipe. The following points should be considered when selecting an expansion joint:

- (a) Because thermal forces developed are much lower than for steel pipe, it is essential to use an expansion joint which is activated by low forces. The force required to compress the expansion joint must not be greater than the force shown in the Compressive End Loads table on page 21.
- (b) In installations where the pipe may operate at a lower temperature than the installation temperature, it may be necessary to pre-set the expansion joint for contraction.

- (c) Guides should be installed to assure that the pipe will remain aligned through the expansion joint. Locate guides not more than 4 times the diameter of the pipe on either side of the expansion joint.

3. Expansion loops. This approach consists of an arc of pipe that flexes to accommodate changes in length. The design method is based on stress developed in a cantilevered beam with a concentrated load at the free end. It ignores flexibility of the loop leg parallel to the pipe line. Guidance for sizing of expansion loops is given on page 20.

4. Anchor supports and guides. For very short pipe runs and/or small changes in temperature, it is frequently unnecessary to make provisions for thermal expansion. The system designer should be aware however, that when pipe is restrained by anchor supports in lieu of providing other means to accommodate expansion, both pipe and anchor supports will be subjected to the end loads shown in the Compressive End Loads table on page 21. Supporting structural steel and steel anchor supports must therefore be capable of resisting these forces. When longer runs of pipe are restrained in this manner, it is necessary to provide guides to keep the pipe line straight, thereby directing forces in an axial direction to prevent buckling which might otherwise occur. Maximum guide spacing is given in the table on page 20. FRP thrust collars are laminated to the pipe on either side of an anchor support to restrain the pipe and are also used with riser

clamps for vertical support. Collars are generally applied while the pipe is being manufactured but can also be applied in the field.

Water Hammer

The high pressure surge or shock load known as “water hammer” is produced by abrupt changes in fluid velocity within the pipe. The usual causes are instantaneous valve closing or opening, as well as pump start-up or shutdown. Pressure gauges, due to slow response time, frequently do not register water hammer pressure surges however violent vibration or movement in the pipeline can sometimes be observed. Complete explanations and calculations for this phenomenon can be found in piping handbooks. Under certain conditions these shock forces can be of sufficient magnitude to rupture a piping system. The system designer is cautioned to take measures to prevent or reduce these forces. One method would be to use slow-closing valves or surge tanks. Additionally, pumps should never be started into empty discharge lines unless valves are used to control flow. A check valve should be installed to control the velocity of liquid flowing back through a line. As a general guideline, **IntegraLine** pipe will withstand a dynamic pressure increase equal to the pressure rating of the pipe, however the system must be adequately anchored and supported, particularly at changes in direction and branch connections, to prevent movement of the pipeline.

Vibration

Although low-amplitude vibration from a well-anchored centrifugal pump will generally have little effect on **IntegraLine** pipe, adjacent supports should be well cushioned to prevent abrasion of the exterior of the pipe. Large amplitude vibration should be isolated from the pipe through the use of flexible connectors.

Hydrostatic Testing

Whenever possible, FRP piping systems should be hydrostatically tested prior to process start-up. Testing with air or gas is extremely hazardous and is not recommended. The following approach to testing the system is suggested:

1. Insure that all supports, guides and anchors are in place and the line is properly restrained.
2. Introduce water to the system at the lowest point, preferably through a 1" diameter or smaller pipe.
3. Provide a means to bleed air off, such as loosening a flange or partially opening a valve, at the highest point in the system.
4. When the system is filled, slowly close the air bleed-off point and gradually bring the system up to the desired pressure.
5. Test pressure should not exceed 1-1/2 times the system operating pressure or 1-1/2 times the rated operating pressure of the pipe.

50 PSI

Diameter	Wall Thickness	Type I	Type II	Type III	Type IV
6	0.21	14.7	16.4	15.8	18.0
8	0.21	13.9	15.6	15.0	17.0
10	0.21	13.0	14.6	14.1	16.0
12	0.21	12.0	13.4	12.9	14.7
14	0.21	10.7	11.9	11.5	13.0
16	0.26	14.8	16.5	16.0	18.1
18	0.26	13.9	15.5	15.0	17.0
20	0.26	12.9	14.4	13.9	15.8
24	0.31	15.7	17.5	17.0	19.2
30	0.31	12.8	14.2	13.8	15.7
36	0.36	15.0	16.8	16.2	18.3

100 PSI

Diameter	Wall Thickness	Type I	Type II	Type III	Type IV
6	0.21	11.5	12.9	12.4	14.1
8	0.24	12.5	14.0	13.5	15.3
10	0.26	13.0	14.5	14.0	15.9
12	0.29	14.0	15.6	15.1	17.1
14	0.31	14.0	15.6	15.1	17.1
16	0.34	15.0	16.7	16.2	18.3
18	0.36	15.5	17.3	16.5	18.9
20	0.41	17.0	19.0	18.3	20.7
24	0.46	18.0	20.1	19.4	22.0
30	0.56	19.5	21.7	21.0	23.8
36	0.62	20.5	22.9	22.1	25.1

150 PSI

Diameter	Wall Thickness	Type I	Type II	Type III	Type IV
6	0.26	11.0	12.3	11.8	13.2
8	0.31	12.5	13.8	13.5	15.2
10	0.31	13.0	14.5	14.0	15.9
12	0.36	14.5	16.2	15.6	17.6
14	0.41	15.0	16.6	16.2	18.3
16	0.45	15.5	17.3	16.6	18.9
18	0.47	16.5	18.4	17.8	20.2
20	0.52	17.5	19.5	18.9	21.3
24	0.58	18.5	20.5	19.9	22.5
30	0.71	20.5	22.5	22.1	25.0
36	0.81	23.0	25.0	24.6	28.0

NOTE: All spans based on fluid contents specific gravity of 1.2

Type I
Simply supported spans (two supports per span length) with the run attached to a fitting at one end, or any other section of less than three span lengths.

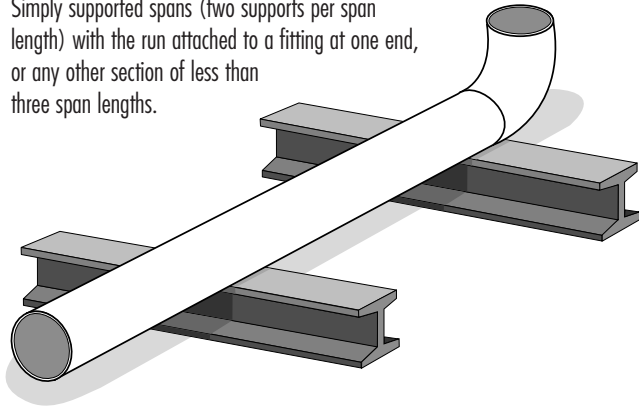

Type II
Continuous beam of three spans, all loaded.

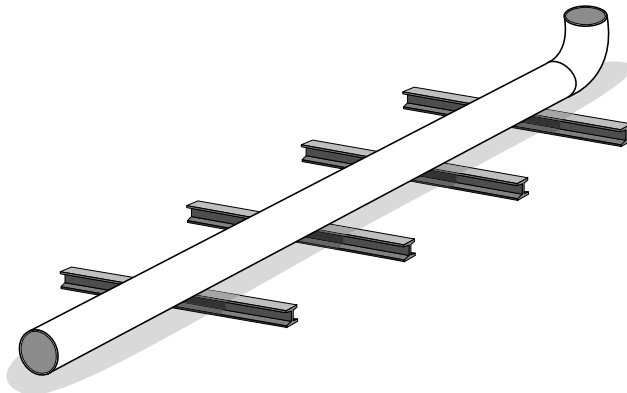

Type III
Continuous beam of four or more spans, all loaded.

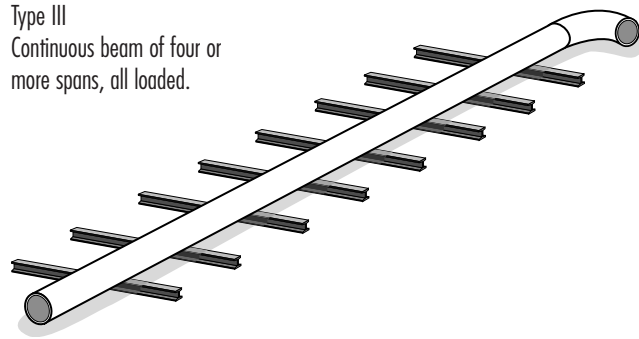

Type IV
Beam fixed at both ends, uniformly distributed loads.

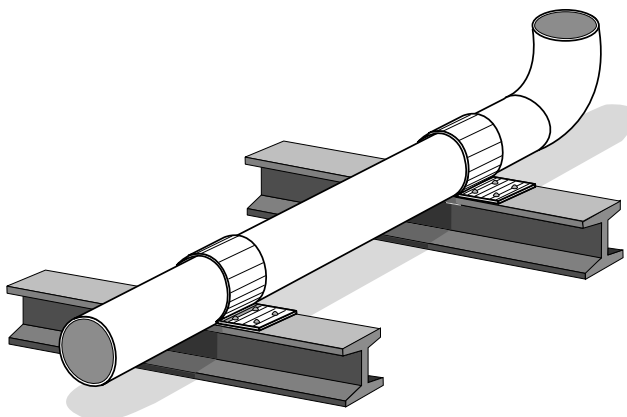

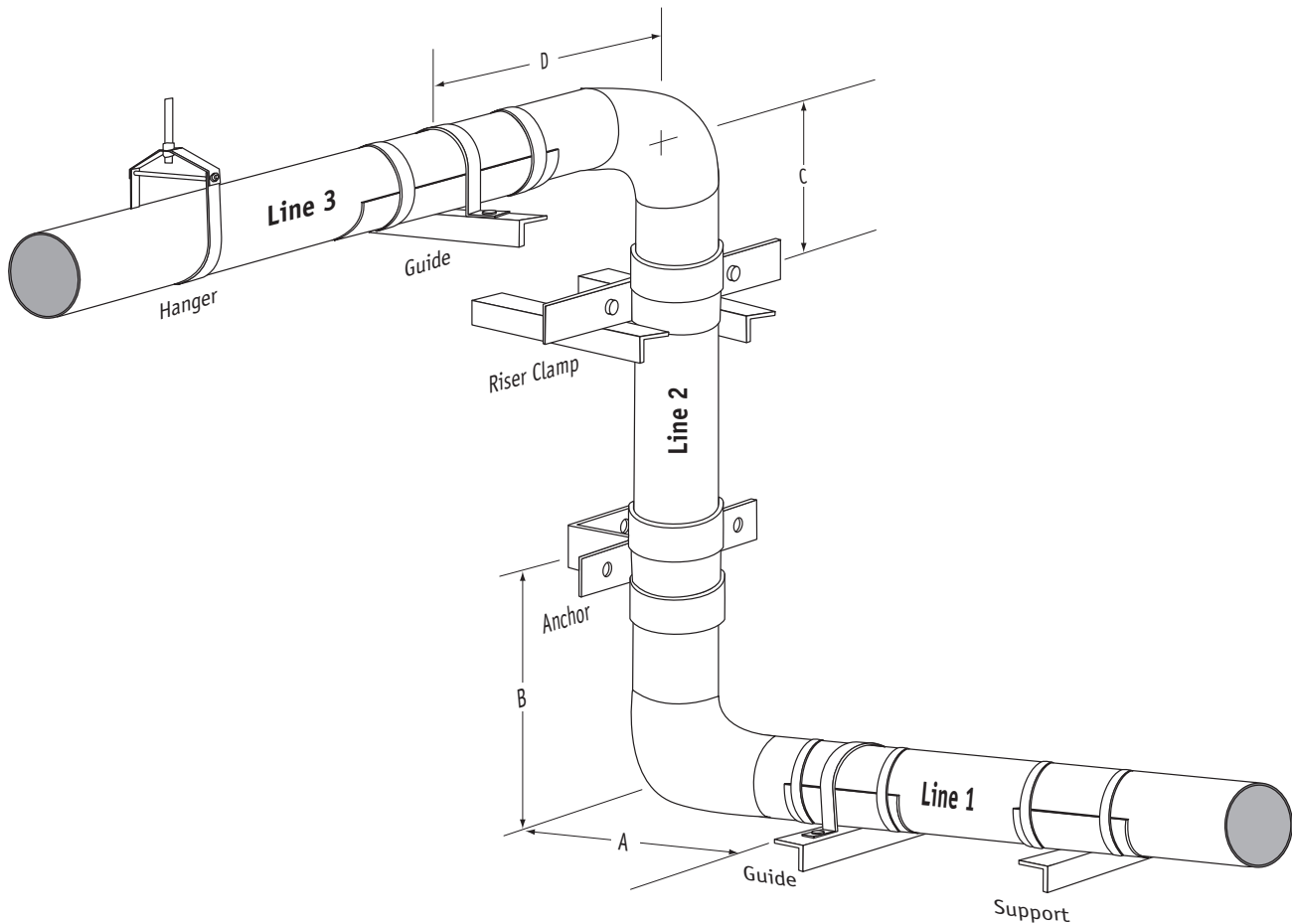

Using System Direction Changes (Offset Legs) to Deal with Expansion

The illustration above depicts a typical installation configuration. To use this particular configuration to advantage in allowing for pipe expansion, the following steps would be appropriate:

1. Using the Linear Thermal Expansion table (Page 19), determine the maximum expansion of line 1 from any prior anchor point. This value is used with the Minimum Length Of Offset Leg table (page 19) to find the minimum length of the offset leg B.
2. Determine the maximum expansion of that portion of line 2 between the anchor support and the lower elbow. This value is then used to find the minimum length of the offset leg A.

3. Determine the maximum expansion of line 3 from any prior anchor point and use this value to find the minimum length of the offset leg C. (Note: If the upper support location on the vertical run did not allow for an adequate distance to the upper elbow, it can be allowed to slide and the distance from the upper elbow to the anchor support then becomes the offset leg.)
4. Determine the maximum expansion from the anchor support to the upper elbow and use this value to find the minimum length of the offset leg D.

NOTES: 1. Generally, the support which satisfies the minimum offset leg length should prevent lateral movement and buckling. A Guide Support is frequently used for this purpose.

2. After determining the minimum allowable distance of the offset leg, check the Allowable Span table (page 16) to determine if additional supports between the elbow and the offset leg guide support are required. These should be sliding supports, allowing for both axial and lateral movement.

3. Steel supports, which satisfy the more commonly encountered requirements, are available from FIBREX and are shown in this manual.

Linear Thermal Expansion

Change in Temperature - Degrees F																	
10	20	30	40	50	60	70	80	90	100	110	120	130	140	150	160	170	180
0.1	0.3	0.4	0.5	0.7	0.8	1.0	1.1	1.2	1.4	1.5	1.6	1.8	1.9	2.1	2.2	2.3	2.5
Change in Length - inches per 100 ft.																	

Minimum Length of Offset Leg

Deflection of Offset Leg - (Linear expansion of main run) - inches																		
	0.5	1.0	1.5	2	2.5	3	3.5	4	4.5	6	6.5	7	7.5	8	8.5	9	9.5	10
Diameter																		
6	7.6	11	13	15	17	19	20	22	23	26	28	29	30	31	32	32	33	34
8	8.8	12	15	18	20	22	23	25	26	31	32	33	34	35	36	37	38	39
10	9.8	14	17	20	22	24	26	28	29	34	35	37	38	39	40	42	43	44
12	11	15	19	21	24	26	28	30	32	37	39	40	41	43	44	45	47	48
14	12	16	20	23	26	28	30	33	35	40	42	43	45	46	47	49	50	51
16	12	17	21	25	28	30	33	35	37	43	44	46	48	49	51	52	54	55
18	13	18	23	26	29	32	34	37	39	45	47	49	50	52	54	55	57	58
20	14	19	24	27	31	34	36	39	41	48	49	51	53	55	57	58	60	61
24	15	21	26	30	34	37	40	42	45	52	54	56	58	60	62	64	65	67
30	17	24	29	33	37	41	44	47	50	58	60	63	65	67	69	71	73	75
36	18	26	32	37	41	45	48	52	55	63	66	69	71	73	76	78	80	82
Length of Offset Leg - feet																		

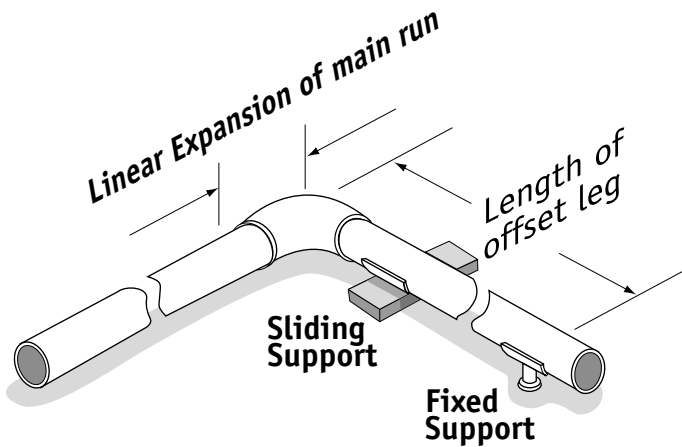

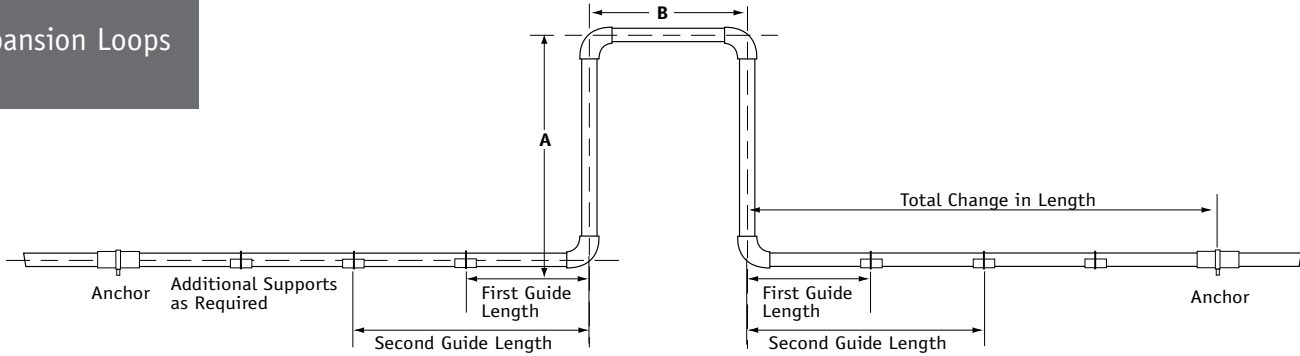

Where straight runs with anchors at both ends are required, system direction changes (offset legs) can be replaced by an expansion loop to accommodate changes in length due to expansion. This is similar to creating “back-to-back offset legs”.

The following steps are used to determine appropriate dimensions for an expansion loop:

1. Determine an available location for the expansion loop. It is not mandatory that the loop is equidistant between the two anchors however to the extent this is possible, the size of the loop will be minimized.
2. Determine the maximum change in temperature between the installation temperature and highest (or lowest) operating temperature.
3. Determine the distance between the expansion loop location and the farther of the two anchor supports.
4. Refer to the Minimum Length Of Offset Leg table (page 19) to determine the minimum length of leg “A”.
5. Leg length “B” should not be less than one half the length of “A”.
6. The distance to the first guide on either side of the loop should be no more than 4 times the diameter of the pipe and distance to the second guide, no more than 16 times the pipe diameter.
7. A support under leg “B” may be provided, however, do not provide any guides within the loop which could constrain pipe movement in the direction of the pipe run.

Maximum Guide Spacing in Feet

Diameter	Change in Temperature - degrees F																	
	10	20	30	40	50	60	70	80	90	100	110	120	130	140	150	160	170	180
6	55	39	32	27	24	22	21	19	18	17	16	16	15	15	14	14	13	13
8	73	52	42	37	33	30	28	26	24	23	22	21	20	20	19	18	18	17
10	90	64	52	45	40	37	34	32	30	29	27	26	25	24	23	23	22	21
12	108	76	62	54	48	44	41	38	36	34	32	31	30	29	28	27	26	25
14	125	88	72	63	56	51	47	44	42	40	38	36	35	33	32	31	30	29
16	143	101	82	71	64	58	54	51	48	45	43	41	40	38	37	36	35	34
18	160	113	92	80	72	65	61	57	53	51	48	46	44	43	41	40	39	38
20	178	126	102	89	79	72	67	63	59	56	54	51	49	47	46	44	43	42
24	213	150	123	106	95	87	80	75	71	67	64	61	59	57	55	53	52	50
30	265	187	153	132	118	108	100	94	88	84	80	76	73	71	68	66	64	62
36	317	224	183	159	142	129	120	112	106	100	96	92	88	85	82	79	77	75

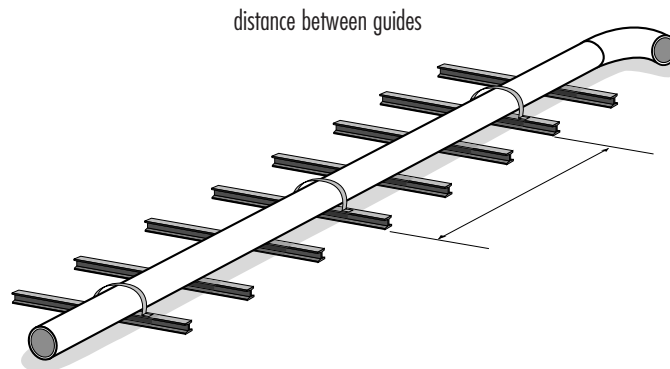

50 PSI

Diameter	Temperature Change - degrees F							
	25°	50°	75°	100°	125°	150°	175°	200°
6	793	1586	2379	3172	3965	4758	5551	6344
8	1060	2120	3180	4240	5300	6360	7420	8480
10	1311	2623	3934	5246	6557	7868	9180	10491
12	1563	3125	4688	6251	7814	9376	10939	12502
14	1814	3628	5442	7256	9070	10884	12699	14513
16	3013	6027	9040	12054	15067	18080	21094	24107
18	3379	6758	10137	13516	16895	20274	23653	27032
20	3745	7489	11234	14978	18723	22467	26212	29957
24	5886	11773	17659	23546	29432	35319	41205	47091
30	7326	14652	21978	29304	36630	43956	51282	58608
36	10867	21735	32602	43469	54337	65204	76071	86939

Restraining pipe expansion with anchors in these temperature ranges will result in excessive axial pipe stresses

100 PSI

Diameter	Temperature Change - degrees F							
	25°	50°	75°	100°	125°	150°	175°	200°
6	793	1586	2379	3172	3965	4758	5551	6344
8	1354	2708	4062	5416	6770	8124	9478	10832
10	1917	3833	5750	7666	9583	11500	13416	15333
12	2717	5433	8150	10867	13583	16300	19016	21733
14	3487	6974	10462	13949	17436	20923	24411	27898
16	4542	9084	13626	18168	22710	27252	31794	36336
18	5521	11041	16562	22082	27603	33123	38644	44164
20	7308	14616	21925	29233	36541	43849	51158	58466
24	10153	20305	30458	40611	50764	60916	71069	81222
30	16179	32357	48536	64715	80893	97072	113251	129430
36	21889	43778	65667	87556	109446	131335	153224	175113

Restraining pipe expansion with anchors in these temperature ranges will result in excessive axial pipe stresses

150 PSI

Diameter	Temperature Change - degrees F							
	25°	50°	75°	100°	125°	150°	175°	200°
6	940	1880	2820	3761	4701	5641	6581	7521
8	1650	3300	4950	6600	8250	9899	11549	13199
10	2650	5301	7951	10602	13252	15903	18553	21203
12	3738	7477	11215	14953	18691	22430	26168	29906
14	4842	9684	14527	19369	24211	29053	33895	38738
16	6279	12558	18838	25117	31396	37675	43954	50234
18	7903	15805	23708	31611	39513	47416	55319	63221
20	9471	18942	28413	37884	47356	56827	66298	75769
24	13603	27206	40808	54411	68014	81617	95219	108822
30	20479	40957	61436	81915	102394	122872	143351	163830
36	30041	60082	90124	120165	150206	180247	210288	240330

Restraining pipe expansion with anchors in these temperature ranges will result in excessive axial pipe stresses

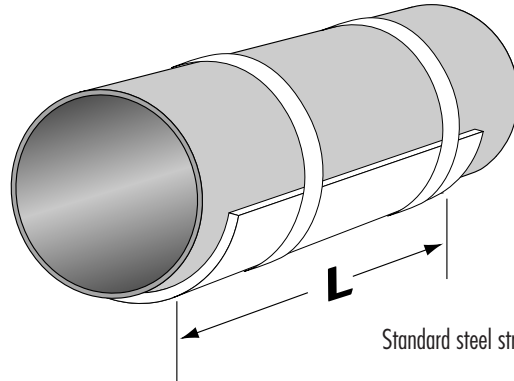

Standard steel strapping for Cradle Support not included.

Cradle Support

Pipe Size	L
6-14	12
16-20	14
24	16
30	20
36	24

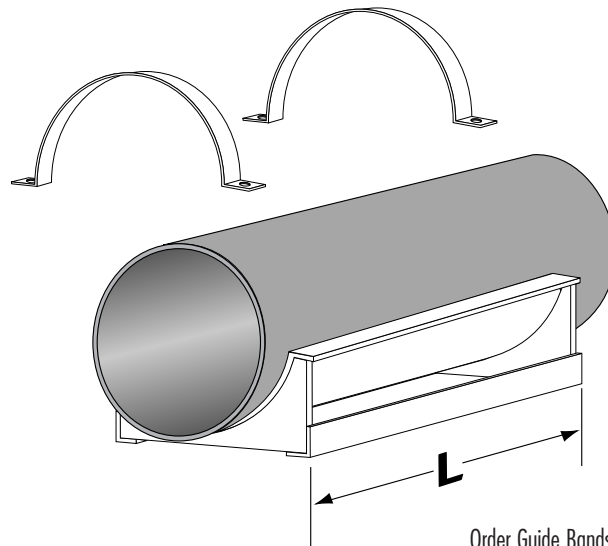

Order Guide Bands separately when required.

Saddle Support

Pipe Size	L
6-10	10
12-16	12
18-20	14
24	20
30	20
36	24

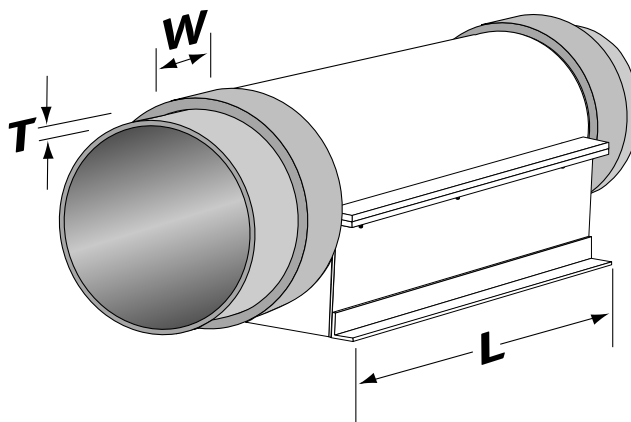

Anchor Support

Pipe Size	L	T	W
6-10	10	1/2	6
12-16	12	5/8	8
18-20	14	5/8	8
24	16	3/4	10
30	20	7/8	12
36	24	1	14

Clevis Hanger

Pipe Size	L
6-14	12
16-20	14
24	16
30	20
36	24

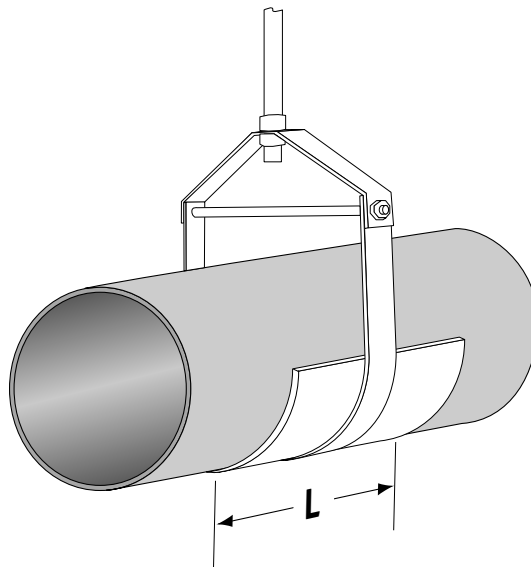

Clamp Hanger

Pipe Size	L
6-14	12
16-20	14
24	16
30	20
36	24

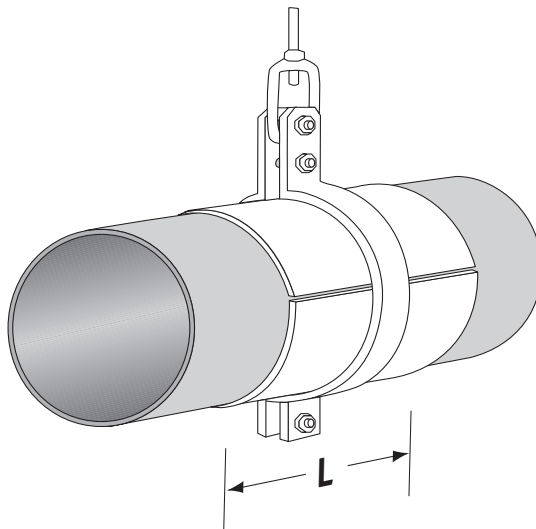

Riser Clamp

Pipe Size	E	T	W
6-10	3	1/2	3
12-16	4	5/8	4
18-20	4	5/8	4
24	6	3/4	6
30	8	7/8	6
36	8	1	8

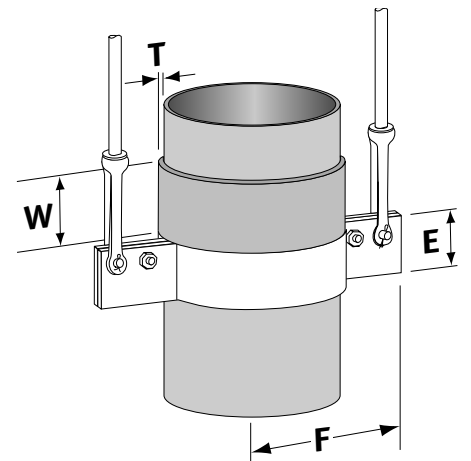
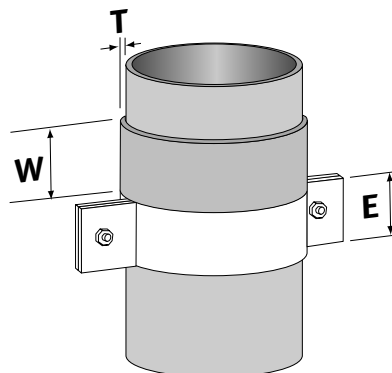

IntegralLine steel supports are available from Fibrex or can be provided by customer.

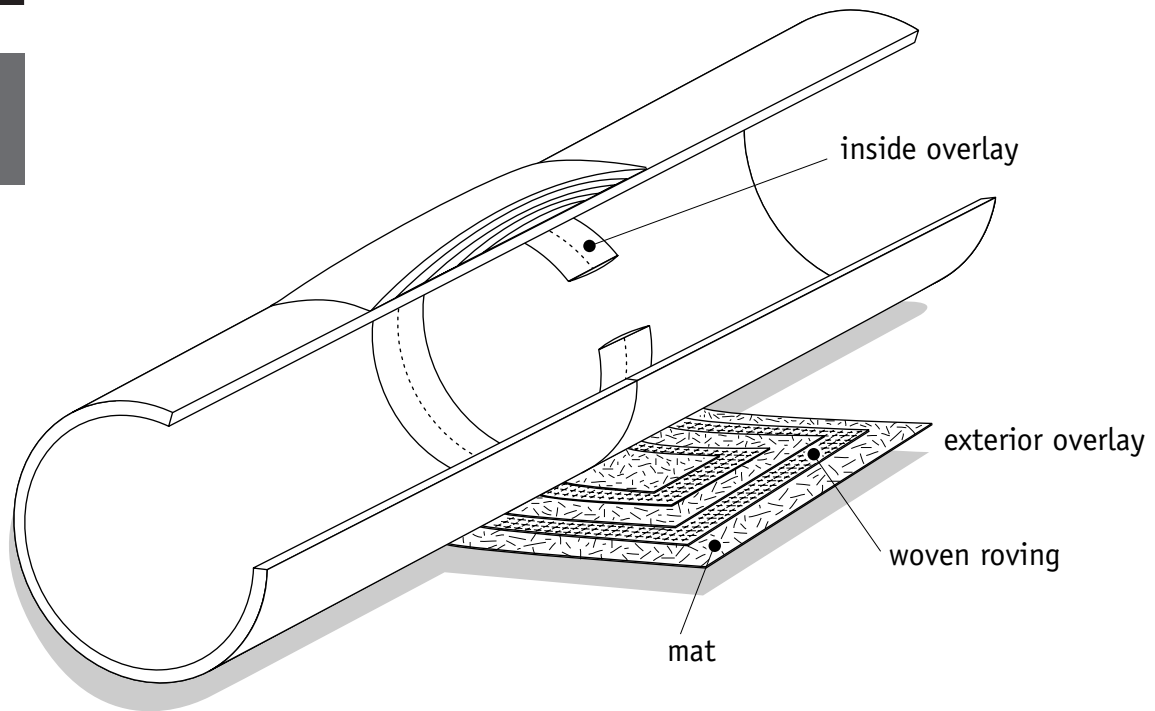

Joining Procedures

IntegralLine pipe makes use of the joint type widely recognized as being the most corrosion resistant and reliable of all currently available means of connecting FRP pipe components... the BUTT JOINT, sometimes also known as the "butt wrap" joint or the "butt and strap" joint. This type of joint is analogous to a weld in metallic piping systems and consists essentially of a "strap" of laminate wrapped around the exterior of the two parts being joined. This joint uses the same materials of construction as the pipe fittings. The result is a homogeneous "weld", without the potential for problems sometimes associated with systems utilizing various adhesives, mechanical components or other materials of dissimilar composition. Since **IntegralLine** pipe is not about compromises, FIBREX strongly recommends the use of the BUTT JOINT rather than seemingly more convenient, but potentially less reliable, alternative types of joints. It may take days to become proficient at welding stainless steel, but it takes only a few hours to become an expert at "welding" FRP pipe.

Before You Start...

you will need:

1. for weighing and measuring

- graduated cylinder (metric)
- weighing scale (25lb to 60 lb capacity)
- floor paper, flexible plastic strip or other material to wrap around pipe

2. for cutting and surface preparation

- power sander and sanding discs (24 grit & 60 grit)
- barrel grinder
- circular saw (diamond coated or carbide grit masonry blade)
- saber saw or hack saw (carbide tip or grit blade) if irregular cuts will be required

3. for applying laminate materials

- stiff bristle brushes
- 3" wide laminating roller (bristle or metal fin)
- 6" wide paint rollers
- scissors
- razor trim knife
- mixing sticks
- putty knife
- several gallon and pint containers
- clean rags
- pails for storage of rollers and brushes in
- cleaning agent
- acetone or water based emulsifier for cleaning tools
- cardboard sheets or floor paper to wet out glass strips

The following step-by-step procedures will produce a no-compromise, “welded” BUTT JOINT assuring the integrity of the system.

1. Wrap the flexible plastic strip, heavy floor paper or other sheet material around pipe to act as a template for marking a true square cut.

2. With pipe properly supported, cut ends square using the circular saw. If irregular cuts are required, use a saber saw or hack saw.

3. Sand the exterior surface of the pipe using a power sander with 24 grit disc to remove all of the resin wax coat for a distance at least 1" beyond the completed strap overlay width.

4. Maximum chemical resistance of the joint is achieved with an INSIDE OVERLAY. This can be provided on all joints where the pipe is large enough to allow entry or the joint can be reached from outside the pipe. If an INSIDE OVERLAY is to be provided, lightly sand the inside of the pipe back a distance 1" beyond the completed inside overlay width. Sanding should not disturb the C-veil in the inner surface of the pipe but merely roughen the smooth mold surface of the resin to allow the INSIDE OVERLAY to bond with it.

5. The cut edges of the pipe should be prepared in the following manner. NOTE: If an INSIDE OVERLAY cannot be provided, protection of the cut edges is particularly important and the following procedure should be performed with due care and attention to detail. If the pipe was cut more than 4 hours previously or has been contaminated with dust or other debris, lightly sand the square edge of the pipe to reveal previously unexposed laminate. Using a stiff bristle brush, coat the cut edges with the appropriate resin formulation so that no glass fibers are exposed and all voids are filled. Two or more coats may be advisable.

6. Align the two sections of pipe to be joined. It is imperative that they are supported firmly enough to prevent any movement after starting lamination (fig. 6).

7. When field joint kits are purchased from FIBREX, the resin will already be promoted and ready to mix in accordance with the following guidelines. Resin for “puttying” will have a thickener in it and resin for the exterior will already have the wax mixed in. These materials are also available from your local DERAKANE distributor, however resin purchased directly from a distributor may not be promoted. Ask the distributor to promote the resin and add thickener, wax and U.V. stabilizer, as required, or promote on site in accordance with resin manufacturer’s instructions (available from the distributor or from FIBREX). NOTE: “Pot life” is the time between catalyzation and set-up. Adjust the quantity of catalyst to compensate for ambient temperature conditions or to provide a desired pot life. The table below is based on an ambient temperature of 70 degrees F. For every 15 degrees above 70 degrees F., the pot life will be cut approximately in half. For every 15 degrees below 70 degrees F., the pot life will be approximately double. If pot life exceeds 1 hour, external heat may be required to produce a complete cure. Using too little catalyst can result in an incomplete cure. Less than 1 part per hundred (1 % or 4.5 cc/lb) is not recommended.

8. Start by mixing an adequate amount of the putty resin to fill any gaps or irregularities and apply it to the joint, forcing it into the crevice between the two pieces of pipe. It is not necessary to force putty all the way to the inside of the pipe as this could result in obstructions to the flow. Scrape any excess off the exterior of the pipe, leaving a smooth surface. If small diameter pipe is being joined, this should be adequate to hold the sections of pipe together.

9. If large diameter pipe is being joined, it is helpful to add HOT PATCHES to assist in holding the pipes together. Cut 3 or more pieces of mat, 2"-3" square, saturate with the hot patch resin and place across the joint in 3 or more places to “tack weld” the pipes together.

10. Before proceeding, jab the putty and HOT PATCHES lightly with a knife point to determine if they are cured. Cured material will be hard. If it is soft or spongy, it needs more time. If it does not get hard it was not properly mixed and the prior steps will need to be done over.

11. If you are applying an INSIDE OVERLAY, take the plies of glass for the corrosion barrier (one C-veil and two mat) and set them aside until after completion of the EXTERIOR OVERLAY. If an INSIDE OVERLAY is not possible, include the corrosion barrier plies with the other plies to be applied to the exterior of the pipe in step no. 12. Prior to commencing the EXTERIOR OVERLAY, check to insure that all prepared surfaces are clean and free of moisture, dirt, oils and waxes. If necessary, hand sand or power sand to remove any contaminants.

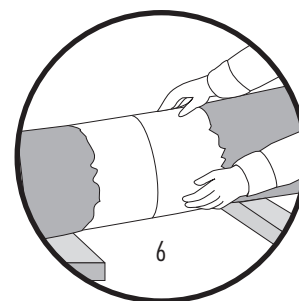

Resin Formulation Chart

	Hot patch & putty resin	Laminating resin	Exterior wax coat resin
Resin	100 parts	100 parts	100 parts
Catalyst (MEKP)	3 parts (10-12 cc/lb)	1 1/4 parts (5-6 cc/lb)	2 parts (8-9 cc/lb)
Pot Life	12 min.	20-40 min.	15-25 min.

12a

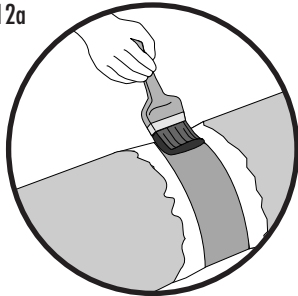

12. Mix the laminating resin and apply with brush or paint roller to all prepared (sanded) areas of the joint (12a). Commence wetting out the glass "strap", working on clean cardboard or floor paper. Start with the narrowest ply (strip) of glass and apply resin to it, rolling until uniformly saturated (12b). Place the glass ply around the joint, being careful to have it centered. (12c), and roll all the air out using a laminating roller, rolling from the center toward the edges of the glass (12d). Add more resin, if necessary, using a brush or paint roller. Repeat this procedure with each consecutively wider glass ply (strip) until the joint is completed. Subsequent layers of glass should lap at different locations around the pipe. Care must be taken to prevent the joint laminate from sagging at the bottom of the pipe during the curing process.

12b

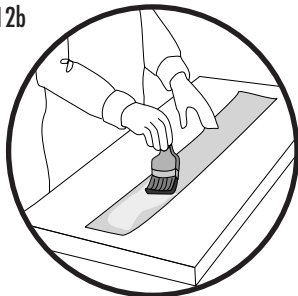

After acquiring an adequate level of experience, you will want to substitute the following procedure, or one like it, for wetting and applying the glass to the joints. This will appreciably speed up the process. Determine how many layers of glass you can apply together at one time. Place the widest on the cardboard or floor paper, apply resin and roll on it to completely saturate it and remove air bubbles. Center the next, slightly narrower glass ply on top of it but offsetting 1/2" - 1" on the length. Apply resin and roll on it. Repeat this procedure with each successive glass ply until the narrowest has been rolled out (12e). Note: when using this procedure, it is more important to roll air out of the laminate while it is still on the cardboard or floor paper. Apply resin with brush or paint roller to all prepared areas of the joint. Lift all plies of glass together and, with the narrowest ply toward the inside, center the strap over the joint seam. Use an even, forward pressure to wrap around the joint, overlapping offset ends smoothly. With thick, large diameter

12c

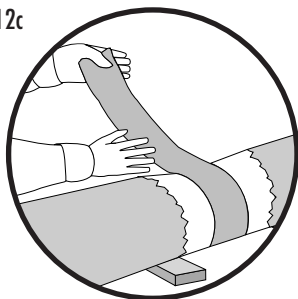

joints, it is often easier to apply this type strap in sections of half, or even one third, of the joint. Roll out, from the center to the edge of the strap, blending the edges into the pipe and removing all wrinkles and entrapped air. Care must be taken to prevent the joint laminate from sagging at the bottom of the pipe during the curing process.

13. Allow the EXTERIOR OVERLAY to cure and then do the INSIDE OVERLAY, if one is to be provided, using the same process as described above. Typically, the EXTERIOR OVERLAYS of several joints are made while previously overlaid joints are curing, before coming back and applying the INSIDE OVERLAYS. Note that the C-veil is applied last on an INSIDE OVERLAY so that it is the layer in contact with the corrosive liquid.

14. Sand off any rough edges before applying the final exterior coat, then mix the exterior wax coat resin. If supplied by FIBREX, this material will have an ultraviolet stabilizer in it as well as the paraffin wax. Apply this resin liberally to the exterior of the joint and inside overlay as well as all sanded areas for maximum corrosion and weathering resistance.

12d

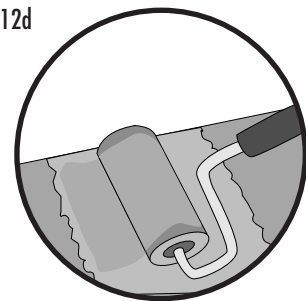

12e

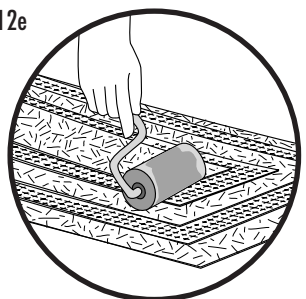

LAYER SEQUENCE

Contact Molded Pipe Wall Thickness	0.19	0.24	0.30	0.35	0.41	0.46	0.52	0.57	0.63	0.68	0.74	0.85	1.07	1.23
corrosion barrier (veil is 10 mil C glass, mat is 1-1/2 oz. per sq. ft.)														
6" wide C-veil	1	1	1	1	1	1	1	1	1	1	1	1	1	1
4" wide mat	2-3	2-3	2-3	2-3	2-3	2-3	2-3	2-3	2-3	2-3	2-3	2-3	2-3	2-3
structural wall (mat is 3/4 oz. per sq. ft. except final layer of 1-1/2 oz per sq. ft., woven roving is 24 oz per sq. yd.)														
4" wide roving	2	2	2	2-4	2-4	2-4	2-4	2-4	2-4	2-4	2-4	2-4	2-4	2-4
6" wide mat	1-3	1-3	1-3	1-3-5	1-3-5	1-3-5	1-3-5	1-3-5	1-3-5	1-3-5	1-3-5	1-3-5	1-3-5	1-3-5
6" wide roving		4	4	6	6	6	6	6	6	6-8	6-8	6-8	6-8	6-8
8" wide mat		5	5	7	7	7	7	7	7	7-9	7-9	7-9	7-9	7-9
8" wide roving			6	8	8	8	8	8	8	10	10	10-12	10-12	10-12
10" wide mat			7	9	9	9	9	9	9	11	11	11-13	11-13	11-13
10" wide roving				10	10	10	10	10	10	12	12	14	14-16	14-16
12" wide mat				11	11	11	11	11	11	13	13	15	15-17	15-17
12" wide roving					12	12	12	12	12	14	14	16	18-20	18-20
14" wide mat					13	13	13	13	13	15	15	17	19-21	19-21
14" wide roving						14	14	14	14	16	16	18	22-24	22-24
16" wide mat						15	15	15	15	17	17	19	23-25	23-25
16" wide roving							16	16	16	18	18	20	26	26-28
18" wide mat							17	17	17	19	19	21	27	27-29
18" wide roving								18	18	20	20	22	28	30-32
20" wide mat									19	21	21	23	29	31-33
20" wide roving											22	24	30	34
22" wide mat											23	25	31	35
22" wide roving												26	32	36
24" wide mat												27	33	37
24" wide roving												34	38	38
26" wide mat													35	39
26" wide roving														40
28" wide mat														41

NOTE: An experienced overlayer can apply several "stacked" layers of resin-saturated material at one time (see par. 12 of "Joining Procedures" on page 26). The number of layers depends on several factors including the diameter of the joint, required working time for roll-out and general site conditions. It is a good idea to start with 4 - 6 layers of mat and woven roving until the procedure can be assessed. Greater or fewer "stacked" layers can

then be applied, as required to attain maximum productivity while still allowing adequate time for proper roll-out of the laminate. In between applications of "stacked" layers, an exotherm, allowing the laminate to harden, is required. 1-1/2 oz. mat can be substituted for the 3/4 oz. mat but the same number of layers must be used. This will result in a thicker joint and will require approximately one third more resin.

Shipping, Handling and Storage

Shipping

IntegralLine pipe is shipped in one of the following ways:

Contract Truckload: Large orders are shipped by contract carrier on flatbed or stepdeck trailers. General dimensional restrictions for shipping pipe spools are 8'-6" wide x 10'-0" high (13'-6" from road) x up to 48'-0" long

Common Carrier (LTL): Smaller orders, too big for UPS, are shipped LTL by common carrier. This type of shipment may be handled more than once during transit and will sometimes require special crating. It may also take longer to reach its destination than either contract trailers or UPS shipments.

UPS: Pipe components may be shipped via UPS with the following restrictions: Maximum weight per package: 150 LBS. Maximum Size per package: 108 inches in length, 130 inches in length and girth combined.

Contact your UPS Customer Service Office regarding availability of interstate service for packages weighing more than 70 pounds. The maximum weight for a Hazardous Materials package is 70 pounds unless further restricted in the UPS Guide for Shipping Ground and Air Hazardous Materials

Measuring Your Package

(a) Measuring your packages for shipment by UPS involves length, which is longest side of the package, and girth, which is the distance around the widest part of the package at a right angle to the length.

(b) If the length plus the girth of a 3 Day Select, GroundTrac, or Ground package exceeds 84", contact your UPS Customer Service Office.

(c) If the length exceeds 108", the package is over UPS length limit and cannot be accepted.

(d) If the length plus the girth exceeds 130", the package is over UPS size limit and cannot be accepted.

Note: When figuring odd shaped components, girth is measured at the widest part. It is safest to picture the size box that would be required, even if it might not be shipped in one, and figure the girth and length on that basis.

Handling and Storage

1. Caution should be used when handling FRP pipe and components to avoid any type of impact. FRP can be damaged internally (cracking and crazing) by abusive handling without exhibiting visible damage to the external surface.

2. When unloading or transporting pipe, each length, bundle (small diameter pipe) or spool should be handled individually. Do not unload by removing side stakes of trailer and allowing pipe to roll to the ground. Leave all plain end or flange protectors in place until pipe is to be installed.

3. When lifting the pipe by crane, a minimum of 3" wide nylon slings should be used in conjunction with a spreader bar. Do not use chains or steel rope slings. Individual lengths of pipe can be lifted from one point if considerable care is exercised. Recommended practice for control and safety is that 20 ft. lengths of pipe should be lifted at two points, about 5 ft. from each end, and 40 ft. lengths should be lifted at two points about 10 ft. from each end.

4. Pipe stored for short term periods prior to installation should be stored on a flat surface free of any debris on which the pipe might inadvertently be placed.

5. Large diameter pipe stored for longer periods can be stacked by the use of saddle chocks. Chocks should be at least 3" wide and 120 degrees of the pipe diameter. Pipes of like diameter may be stacked by using chocks both under and over the pipe to stabilize the sides and prevent ovaling. Saddle chocks should be no more than 10 ft. on center.

6. Small diameter pipe, and large diameter pipe not being stacked, may be stored by placing directly on 6" wide racks or bearing boards. It is suggested that all pipe be supported on no more than 10 ft. spans with excess overhang divided equally between each end.

7. All field joint kits, resins and curing agents should be stored in a cool, dry place. DERAKANE resins should be stored between 50 and 75 degrees F., out of direct sunlight and away from all heat sources that might create localized hot spots on the resin container.

UPS Shipment Limitations

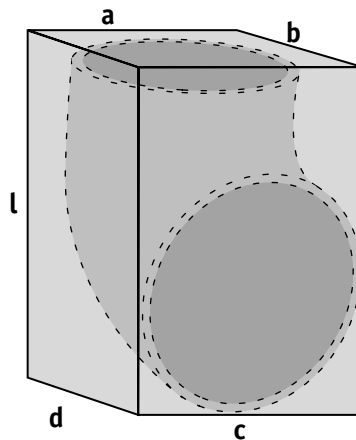

$a + b + c + d = \text{girth}$
 $L = \text{length}$
Maximum length = 108"
Maximum length and girth = 130"

Notes:

Lined area for notes with horizontal ruling lines.

The information in this manual is derived from industry sources in addition to engineering design specific to the products described. There are many years of successful service of FRP pipe upon which the information and recommendations contained herein are based, but FRP pipe must be selected, installed and used in accordance with proven industry practice, common sense and sound judgment.

Further, the information contained in this manual must be considered as an expression of guidelines based on the sources and practices described above rather than a warranty for which Fibrex assumes responsibility. Fibrex offers separately, a limited warranty of its products, a copy of which is available upon request. In certain instances, Fibrex may provide direct engineering of a proposed installation or will assist in obtaining third party design engineering for specific projects that require it. The information contained in this manual cannot ensure, in itself, a successful installation and is offered to customers subject to these limitations and explanations.

Fibrex reserves the right, without notice, to change the specifications, design or other recommendations in this manual or other Fibrex literature without incurring any obligation for pipe or other equipment previously purchased from Fibrex. Information and descriptions contained in this manual are for the purpose of identification and neither limit nor extend the standard product limited warranty.